

Floor Light

INSTRUCTION MANUAL

Safety Warnings

- This product is only suitable for connection to a 220-240V~50Hz supply in accordance with current IEE wiring regulations. It is for indoor use only, and not suitable for a bathroom location.
- This fitting is a Class II, Double Insulated product  and does not require an Earth. Live or Neutral **must not** be connected to Earth.
- Do not plug into the mains until your lamp is fully assembled.
- Under no circumstances must this table lamp be covered with any material as this could pose a safety hazard. It must be used on a stable, flat surface.
- This product is not suitable for persons under 14 years of age.
- Never fit bulbs of a higher wattage than those specified on the label (as these may cause overheating and damage the fitting). The stem contains non-replaceable LEDs. If the LEDs become damaged the unit must be replaced.
- The lamp must be protected by a 3 amp fuse in the mains plug. If the mains cable becomes damaged it must only be replaced by a technically competent, qualified person.
- If you are in any doubt about your competence please consult a qualified electrician.
- If any modification is made it will invalidate the warranty and may render the product unsafe.
- Allow 10 minutes to cool before replacing, adjusting or cleaning. Clean with a dry cloth only. Do not use liquid or abrasive cleaners on this product.

Assembly/ User Instructions

Before you start

Please read these instructions carefully before fitting and retain for reference. Check the packaging and make sure that you have all the required parts. Follow each assembly step in order to prevent incorrect assembly. Ensure that the product is fully assembled as illustrated before use.

These assembly diagrams are intended as a guide – if in doubt consult a qualified electrician.

1. Carefully unpack your lamp, and place on a stable, flat surface.
2. Screw the bottom section of the stem (1) into the top (2), and then into the base. Secure the base using the spanner provided (3).
3. Gently tug the electric wire (4) through, ensuring it is not trapped or strained.
4. Secure the wire with the plate and screws (5), then affix the self-adhesive base pad (6) in place.
5. Secure the shade (8) with the shade ring (9).
6. Install the bulb (10). Do not install a bulb with a greater wattage or different shape than specified on the label.
7. Plug in, and operate the lampholder switch to turn the main lamp on. Touch the stem sensor to switch the LEDs on. Repeated touches will increase the brightness and ultimately switch the LEDs off. If your lamp will not illuminate, please check the bulb, the 3 amp fuse in the plug and ultimately check the relevant fuse in your fuse box. If unsuccessful please consult your Retailer.

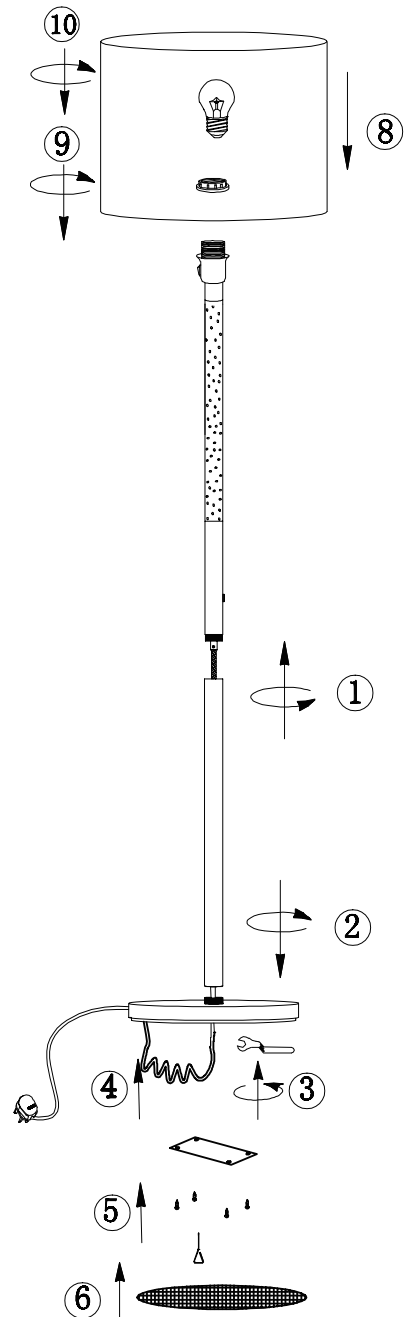

- EN Scan QR code for multi-language
- FR Scannez le code QR pour plusieurs langues
- ES Escanee el código QR para varios idiomas
- PL Zeskanuj kod QR dla wielu języków
- DE Scannen Sie den QR-Code nach mehreren Sprachen
- IT Scansiona il codice QR per multilingua